

## TD6500

### Magnetostrictive Start / Stop Controller



- 1/8 DIN Case • 5-button Programming
- 6-digit, 0.56" (14.2 mm) Alphanumeric Display

#### Specifications

TDC .....	ACAM Time-to-digital convertor 250 ps time resolution (typical).
Multi-hit Capability .....	Up to 4 independent magnets read concurrently (representing 4 displacements).
Transducer Interface.....	Start / Stop (RS422 differential). Typically leading edge, but can be leading or trailing edge.
Signal Proc. Rate .....	100 Hz.
Units .....	Select inches or millimeters.
Max. Sensor Length .....	Inches: 165. Meters: 4.
Resolution .....	Inches: 0.01, 0.001, or 0.0001. Millimeters: 0.1, 0.01, or 0.001.
Number of Magnets .....	One to four.
Count Direction.....	Positive or negative.
Gradient .....	Inches: 8.0000 to 11.0000 (µs/inch). Millimeters: 2000.0 to 3500.0 meters/sec.
Home Position .....	Magnet 1: from -199999 to 999999 counts.
Displacement .....	Selectable 1-4 independent position calculations.
Velocity .....	Selectable 1-4 independent velocity calculations.
Relay Outputs.....	Up to six 5 A relays, or combinations of 10 A and 5 A relays. Contact Transducers Direct for details.
Setpoint Control .....	Choice of 6 setpoint sources and inverted logic for latched digital outputs.
Analog Output.....	Single Output: Fully scalable, isolated 16-bit from 0 to 10 VDC (or reverse), or 0/4 to 20 mA (or reverse). Dual Output: Fully scalable, 16-bit dual 0 to 10 VDC (or reverse), sharing common 0.
Serial Output.....	Choice of either RS-232 or RS-485.
Advanced Functions.....	A number of advanced functions are available and can be added at minimum cost. See Page 22.

#### Introduction

The TD6500 is a magnetostrictive start / stop interface with a 6-digit alpha-numeric display contained in an 1/8 DIN case. The modular construction of the TD6500 allows for a variety of relay, analog, and serial output options using plug-in type output cards.

The five button format provides instant access to the following programming menus. Once the output options have been configured in the main programming mode, magnetostrictive settings relevant to a specific sensor can be easily configured through the main and setpoint menus by pressing the **P** or **F2** button. These menus provide easy to use message prompts to configure the TD6500 for up to four magnet displacement inputs.

- P** — **Main Menu** — Provides easy-to-use message prompts to configure the TD6500 for up to 4 magnets.  
4 secs
- F2** — **Setpoint Menu** — Provides easy-to-use message prompts to configure up to 6 simple setpoint and relay settings.
- F1** — **Set Home Position** — Allows you to set a physical start or 'home' position for magnet 1.
- P** **↑** — **Main Programming Mode** — This mode contains all the menus to configure the built-in functions of the controller, including the analog and serial output settings.
- P** **↓** — **Setpoint Programming Mode** — This mode contains all the menus to configure the controller for sophisticated setpoint and relay settings, including hysteresis, deviation, timers, and much more.
- ↑** — **View Mode** — This mode allows you to view the positions of all the magnets.
- ↓** — **View Mode** — This mode allows you to view the activation settings of all six setpoints.

## Main Menu

The main menu is where the magnetostrictive sensor settings are configured using easy-to-follow message prompts that guide you through all relevant settings. When changing sensors, reconfiguration is easily carried out by pressing the **P** button for 4 seconds and entering the main menu. The message prompts lead you through the following menus.

### Main Menu Logic Tree

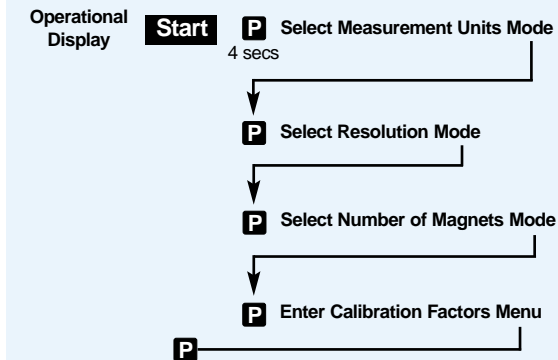

### Select Measurement Units Mode

This menu allows you to select the unit of measurement for all other settings. If you select inches in this menu, then all other menus ask for settings to be entered in inches. Conversely, if you select millimeters in this menu, then all other menus ask for settings to be entered in millimeters [MM].

### Select Resolution Mode

This menu allows you to select the resolution of the display positional readings in either hundredths (0.01), thousandths (0.001), or ten thousandths (0.0001) of an inch. Or, if set to millimeters as the measurement unit in either tenths (0.1), hundredths (0.01), or thousandths (0.001) of a millimeter.

### Select Number of Magnets Mode

This menu allows you to select the number of magnets you require for your application. You can select from one to four magnets.

### Enter Calibration Factors Menu

This menu allows you to configure calibration factors in the following sub-menus.

#### Select Count Direction Menu

This menu allows you to configure the controller to read in **positive** or **negative** units from the home position of magnet 1. Magnet 1 is the magnet closest to the transducer's zero / null position (normally shown by a groove cut in the transducer mounting rail).

#### Select Transducer Type Menu

This menu allows you to select the type of transducer installed. The transducer type is normally shown on the transducer nameplate as part of the serial number: either **T** for trailing edge or **L** for leading edge.

## Set Gradient Menu

This menu allows you to set the gradient setting in either micro seconds per inch or meters per second, depending on the units selected in the **select measurement units mode**. When set to the default resolution, the minimum to maximum gradient setting is 8.0000 to 11.0000 microseconds/inch or 2000.0 to 3500.0 meters/second.

The gradient for the transducer is normally shown on the transducer label.

## Set Home Position Menu

This menu works together with the **F1** button. It allows you to set a physical start or 'home' position and a display home position setting for magnet 1.

The display home position setting can range from -199999 to 999999 counts. When the display home position has been configured, move magnet 1 to its physical home position and press the **F1** button. This resets the display to the configured home setting for magnet 1.



### CAUTION:

This is a one-time setting for magnet 1. Button **F1** should not be pressed again while the process is in operation. The home setting should only be reset at the beginning of a new process.

## External Switches

### Program Lock Pin

To prevent tampering or inadvertent changes to settings, connecting the PROGRAM LOCK pin (pin 8) to the COMMON pin (pin11) locks all macro and operating system code menus and also the home position. All readings can still be viewed in the view modes.

### Capture Pin

Connecting the CAPTURE pin (pin 12) to the COMMON pin (pin11) performs the same function as the F1 button. The switch must be made for at least 300 ms on the down edge for the home position to be set.

## Setpoint Menu

The setpoint menu is where simple setpoint settings are configured using easy-to-follow message prompts that guide you through the following menus.

### Setpoint Menu Logic Tree

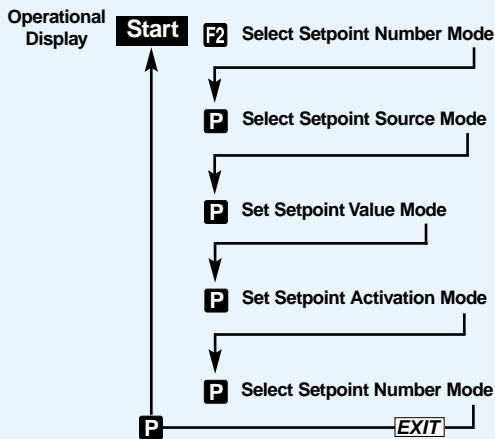

## Select Setpoint Number

This menu allows you to select one of the six available setpoints and applies the following menu settings to it. All six setpoints can be configured in this way. When one setpoint has been configured, return to the operational display and then enter the setpoint menu again by pressing the **F2** button.

## Select Setpoint Source

This menu allows you to select the activation source for the selected setpoint from one of the following settings. Note, the number of sources available depends on the number of magnets selected:

1 Magnet	2 Magnets	3 Magnets	4 Magnets
[MAG_1]	[MAG_1]	[MAG_1]	[MAG_1]
[VEL_1]	[MAG_2]	[MAG_2]	[MAG_2]
	[VEL_1]	[MAG_3]	[MAG_3]
	[VEL_2]	[VEL_1]	[MAG_4]
	[M2 - M1]	[M2 - M1]	[M2 - M1]
		[M3 - M2]	[M3 - M2]
			[M4 - M3]

### Note:

- [MAG\_1] = Position of magnet 1
- [VEL\_1] = Velocity of magnet 1
- [M2 - M1] = Position of magnet 2 minus position of magnet 1

## Set Setpoint Value

This menu allows you to set the value that the selected setpoint activates at. This value can be anywhere from -199999 to 999999 counts.

## Set Setpoint Activation

This menu allows you to select how the selected setpoint is activated, either below the setpoint value [LOW] or above the setpoint value [HIGH].

## Exiting the Setpoint Menu

When the four setpoint settings are configured, the menu returns to the [SET SETPOINT NUMBER] menu. To exit the setpoint menu, press the **↓** button. When [EXIT] is displayed, press the **P** button. The meter returns to the operational display.

## Main Programming Mode

This mode has nine built-in code menus to configure all the functions contained in the controller. Only the following modes should be entered for TD6500 configuration settings:

- **Calibration Mode [CAL]**
  - Serial Port Settings.
  - Analog Output Calibration.
- **Code 1**
  - Data Source for Serial Port.
  - Data Source for Analog Output.
- **Code 3**
  - Select ASCII Mode.

## Setpoint Programming Mode

The setpoint programming mode provides sophisticated setpoint settings that include setpoint latching, reset, tracking, hysteresis and deviation, PID, and seven timer modes. These are advanced setpoint settings. For full details contact Transducers Direct.

## View Modes

The view mode allows you to display the positional readings of all installed magnets. The positional reading for magnet 1 is displayed when the controller is in the operational display.

You can change the reading displayed in the operational display from magnet 1 to any of the following view mode displays. This depends on the number of magnets required and selected for the application. The list is for the maximum of four magnets:

- **[MAG\_1]**
  - This displays the positional reading of magnet 1.
  - The magnet 1 reading is the default operational display.
- **[MAG\_2]**
  - This displays the positional reading of magnet 2.
- **[MAG\_3]**
  - This displays the positional reading of magnet 3.
- **[MAG\_4]**
  - This displays the positional reading of magnet 4.
- **[VEL\_1]**
  - This displays the velocity of magnet 1.
- **[VEL\_2]**
  - This displays the velocity of magnet 2.
- **[M2 - M1]**
  - This displays the position of magnet 2 minus the position of magnet 1.
- **[M3 - M2]**
  - This displays the position of magnet 3 minus the position of magnet 2.
- **[M4 - M3]**
  - This displays the position of magnet 4 minus the position of magnet 3.

To change the reading on the operational display from [MAG\_1] to one of the above displays, press the **↑** button until the display you require appears. Press the **P** button, the new reading now becomes the operational display.

### 1 Magnet Selected



### 2 Magnets Selected

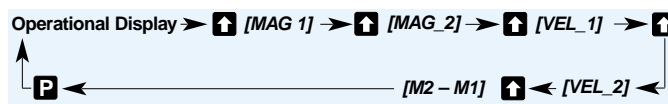

3 and 4 Magnets Selected continued on next page

### 3 Magnets Selected

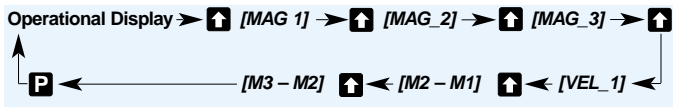

### 4 Magnets Selected

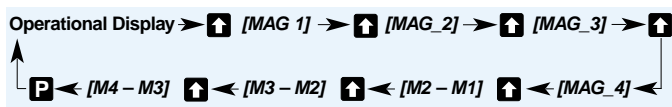

## Message Prompt Menus

### Main Menu Logic Diagram

The **main** and **setpoint** menus provide instant access to easy-to-use message prompts to configure the TD6500 for up to 4 magnets and 6 simple setpoint settings.

Once the output options have been configured (analog and serial output), magnetostrictive settings relevant to a specific sensor can be easily configured through the main and setpoint menus by pressing the **P** or **F2** button.

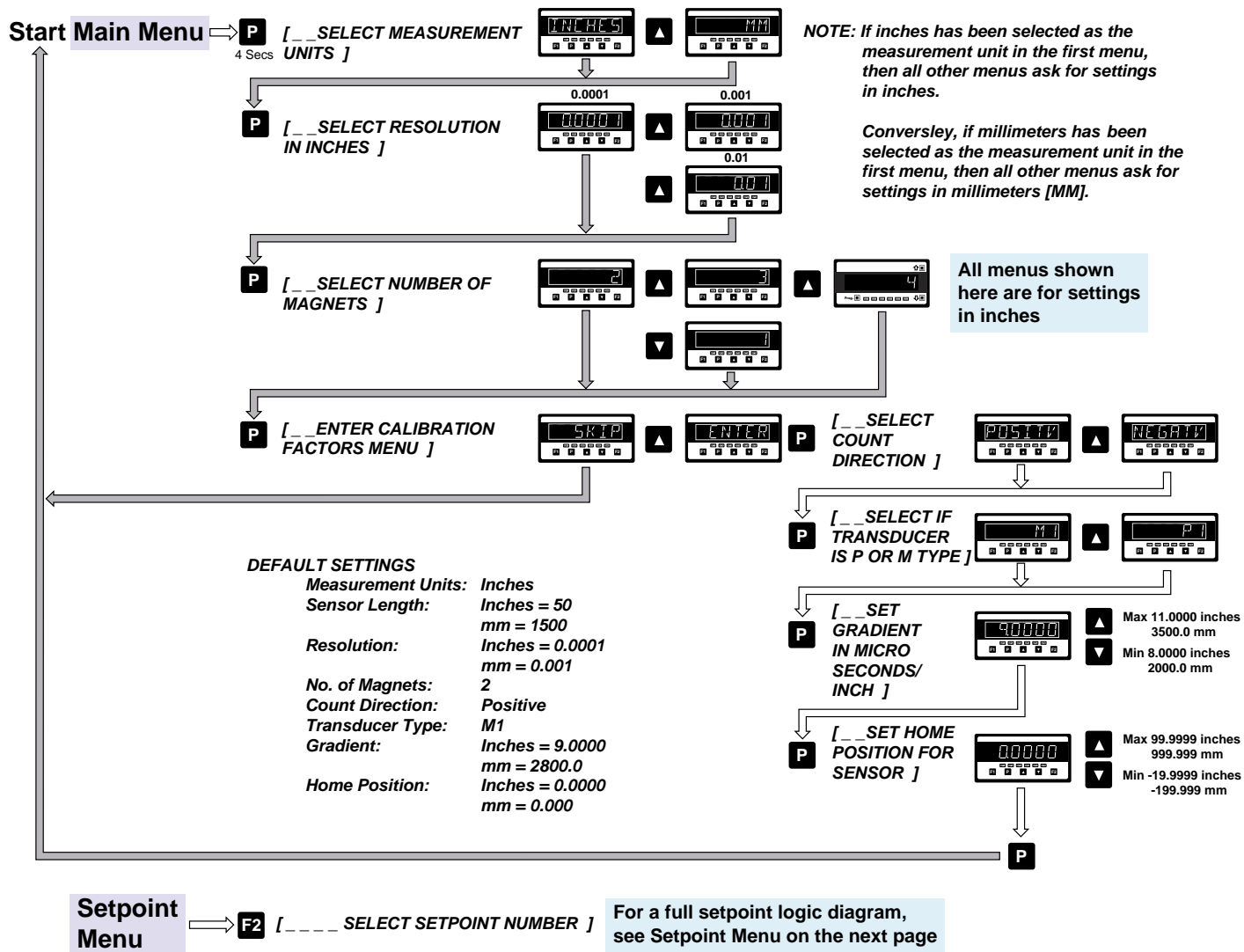

# Setpoint Menu Logic Diagram

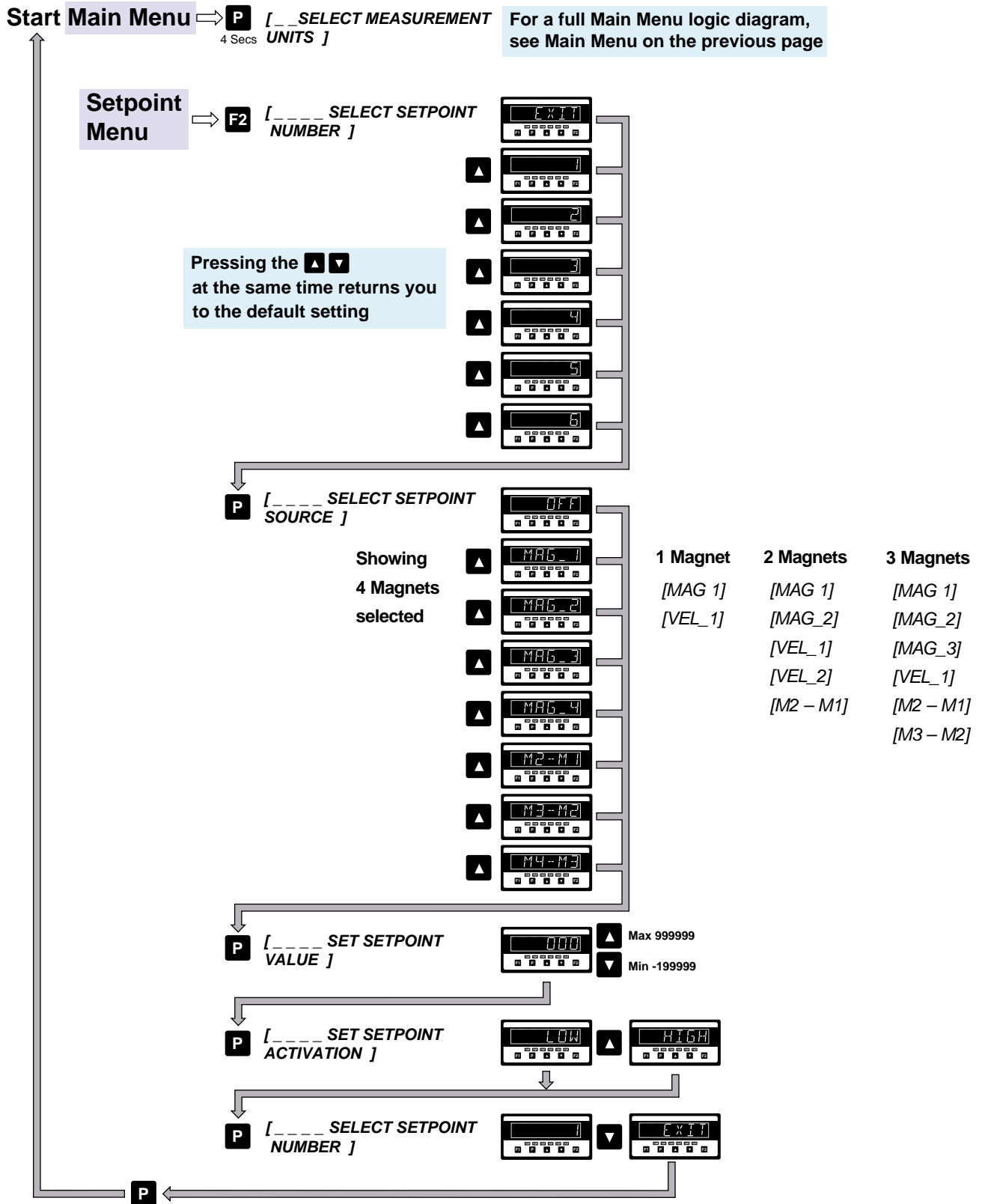

# Analog Output Description

An optional single or dual analog output module is mounted on the meter's output carrier board. The single version is a single channel, programmable, isolated 16-bit analog output that can be scaled to any desired span within the full scale range of the controller. It is user configured using a current / voltage selection header for either 0/4-20 mA or 0-10 V DC.

The dual version has two independently programmable, 16-bit analog output channels with a common 0. They are hardware configured for 10-0-10 V DC. Note, the analog output channels of the dual version must not be confused with the four input channels of the controller.

For example, the data source for analog output 1 could be input channel 3, while the data source for analog output 2 could be input channel 1.

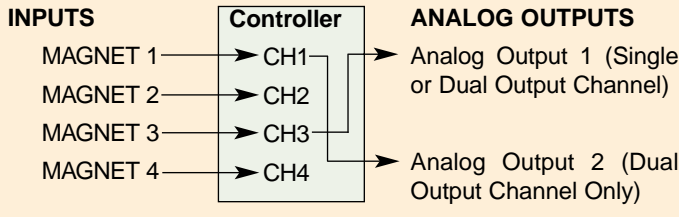

Like the single version, both analog outputs of the dual version can be scaled to any desired span within the full scale range of the controller.

The data source for the analog output can be selected from any processed input signal, but is normally a magnet position or velocity reading on one of the four input channels. The span range of the analog output can be as small as 100 counts between the low and high analog output signal.

Once calibrated, the span range of the analog output can be easily changed (rescaled) without having to recalibrate the output. The low and high analog output signal values (mA or volts) follow the new span range.

## Analog Output Configuration

The single analog output version requires hardware and software configuration, while the dual analog output version only requires software configuration.

### Hardware Configuration

On the single analog output version select the current or voltage position on the analog output selection header.

See *Selection Header Positioning for a procedure.*

### Software Configuration

On the single and dual analog output versions the analog output requires the following settings to be configured in the main programming mode:

- **Calibration Mode:** Scale and calibrate the analog output.
- **Code 1:** Select the data source.

The calibration and data source settings are configured by setting the three right-hand digits on the display to the settings shown in the diagram below.

See *Analog Output Procedures for a set of procedures to:*

- *Position the selection header (single analog output version only).*
- *Scale the analog output.*
- *Calibrate the analog output.*
- *Select the analog output data source.*

### Main Programming Mode

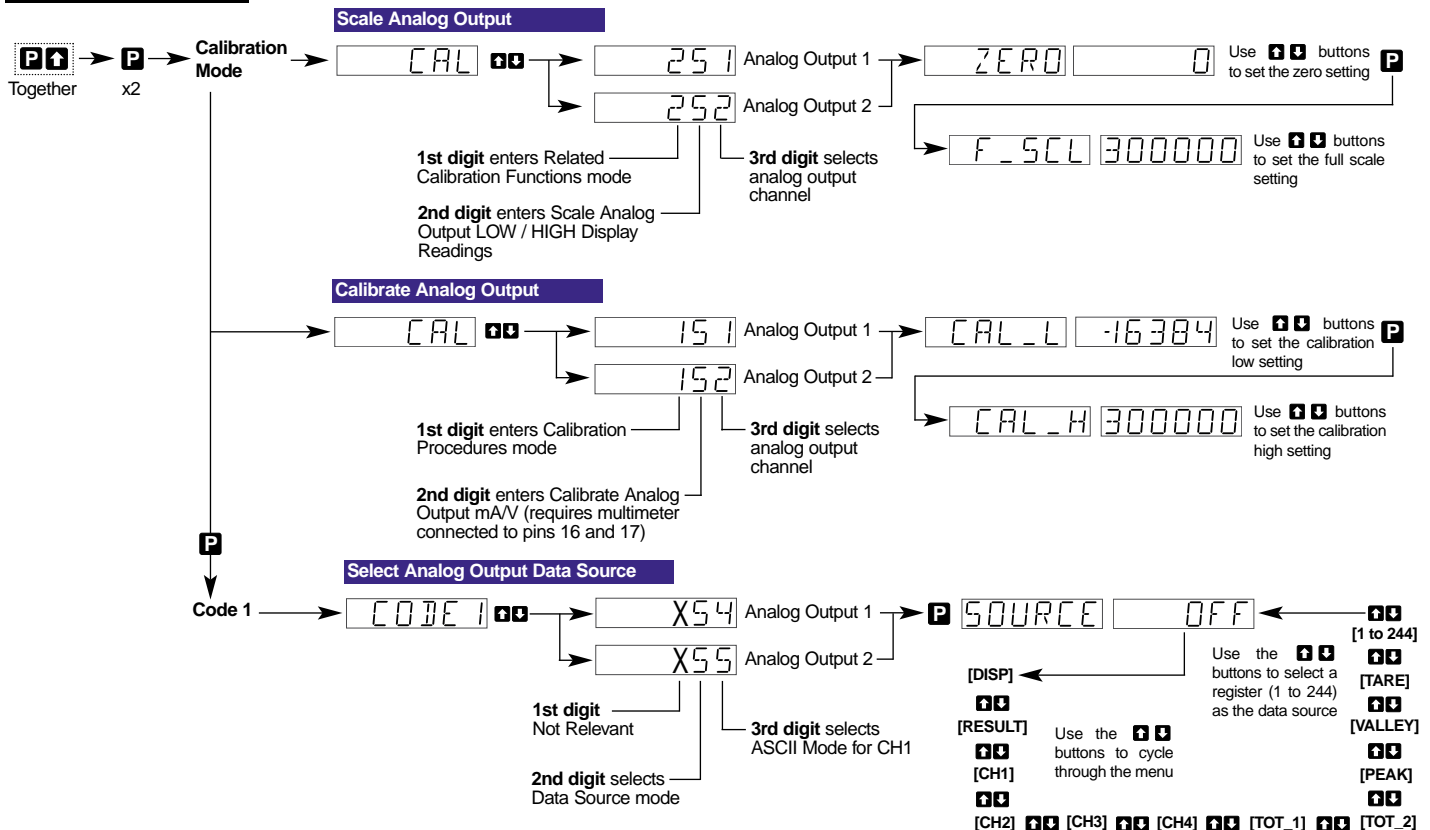

## Selection Header Positioning



**Note:**

*This procedure is only relevant to the single analog output version.*

The analog output selection header can be positioned for current (0/4 to 20 mA) or voltage (0 to 10 VDC) output. To change the header selection, the output carrier board must be removed from the meter. See Figures 1 and 2.

To reposition the analog output selection header, proceed as follows:

**STEP A Disconnect the Power Supply and Input/Output Connectors**

**WARNING**



**AC and DC power supply voltages are hazardous. Make sure the power supply is isolated before disconnecting from the meter.**

- 1) Pull the AC power supply connector block from the AC power input pins.
- 2) Pull all other input and output connectors from their sockets.

**STEP B Remove the Rear Cover from the Meter**

- 1) Using a small flat-blade screwdriver, press down lightly to release the catch on the top of the case and gently lever outwards.
- 2) Repeat for the other top catch.
- 3) With both top catches free, pull the rear cover away from the meter.

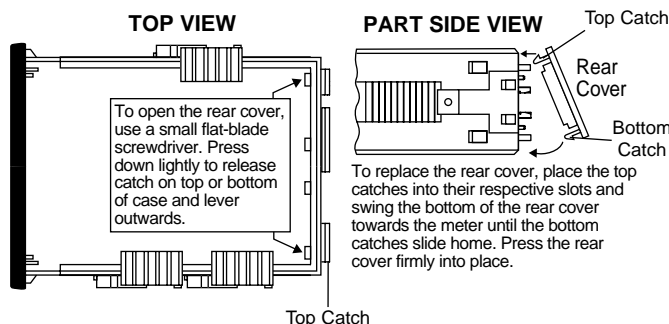

**Figure 1 – Rear Cover Removal**

**STEP C Remove the Carrier Board**

- 1) Pull the carrier board (top board) until it is free from the meter case.

**STEP D Select the Correct ANALOG OUTPUT SELECTION HEADER Setting**

- 1) If not in the correct position, pull the header from its pins and reposition it to suit the analog output signal: VOLTAGE or CURRENT.

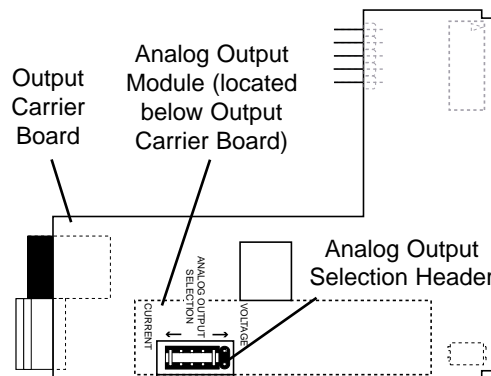

**Figure 2 – Analog Output Selection Header Placement**

**STEP E Replace the Carrier Board**

- 1) Gently push the carrier board back into the meter case, taking care to correctly align the board with the slots on the meter case.

**STEP F Replace the Rear Cover**

- 1) Place the top catches into their respective slots and swing the bottom of the rear cover towards the meter until the bottom catches slide home.
- 2) Press the rear cover firmly into place.

**STEP G Reconnect the Power Supply and Input/Output Connectors**

- 1) Ensure the power supply is still isolated.
- 2) Reconnect the AC power supply connector block to the AC power input pins.
- 3) Reconnect the input and output connectors.
- 4) Remove the isolation from the power supply.

**The power and input signal should be restored and the meter should be in the operational display.**

# Analog Output Calibration Procedures

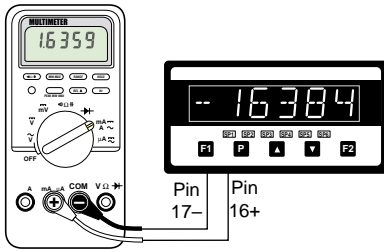

Figure 3 – Multimeter to Meter Connections

## Calibration Setup Procedure

The calibration procedure is in two parts: scaling the low and high display settings and then calibrating the mA / V output. Scaling can be changed independently of calibration and vice versa.

- 1) See Figure 2. Make sure the ANALOG OUTPUT SELECTION HEADER on the analog output module is set in the appropriate position: VOLTAGE or CURRENT.
- 2) See Figure 3. Connect a multimeter to the analog output connector at the rear of the meter (pin 16-positive, pin 17-negative).
- 3) Make sure the multimeter is set to read the appropriate signal type: volts or milliamps.

Scaling the analog output requires the zero [ZERO] and full scale [F\_SCL] parameters to be set.

Zero is the setting at which the analog output is required to be at its calibrated **low** output. Full scale is the setting at which the analog output is required to be at its calibrated **high** output.

There are no limits to the difference between the zero and full scale settings. The difference can be anywhere between 1 count and the entire display range of the meter.

Calibrating the analog output requires setting the [CAL\_L] and [CAL\_H] parameters. [CAL\_L] is used to set the calibrated low output, and [CAL\_H] is used to set the calibrated high output. The calibrated low and high outputs can be set anywhere between -0.3 to +21 mA for current or -0.3 V to +10.5 V for voltage.

## Example

In the following example procedure, we describe how to calibrate the analog output signal for 4 to 20 mA over the scaled range of 50 to 3000 counts. With a display of 50 counts, the analog output must be 4.000 mA. With a display of 3000 counts, the analog output must be 20 mA.

Steps 1 to 8 describe how to scale the analog output using the [ZERO] and [F\_SCL] settings, and Steps 9 to 19 describe how to calibrate the analog output's mA / V output using the [CAL\_L] and [CAL\_H] settings.

## Scale Analog Output

**START HERE**

Operational Display

**Step 1**  
Enter Brightness Mode  
Press at same time

**Step 2**  
Pass Brightness Mode and enter Calibration Mode  
Press 1

**Step 3**  
Set CAL to [251]:  
1st Digit = 2 Selects Related Calibration Functions  
2nd Digit = 5 Selects Scale Analog Output  
3rd Digit = 1 Select Analog Output 1 for Scaling

**Step 4**  
Enter [ZERO] setting mode  
Press 1

0	-
1	- Analog Output 1
2	- Analog Output 2
3	-
4	-

From Step 4

**Step 5**  
Adjust the display to 0.0 low analog output signal counts  
OR

**Example**

**Step 6**  
Enter the [F\_SCL] Setting mode  
Press 1

**Step 7**  
Adjust the display to 500.0 high analog output signal counts  
OR

**Note:**  
The scale settings may be changed at any time without having to recalibrate the analog mA / V output signal.

**Step 8**  
Press 1 Save scale settings (zero and full scale). To return directly to the Operational Display, proceed to Step 17.

**Calibrate the Analog Output Signal**  
continued on next page (Step 9).

Configure Analog Output Procedure continued from bottom of previous page

Step 9

Set CAL to [15X]:  
 1st Digit = 1 Selects Calibration Procedures  
 2nd Digit = 5 Selects Calibrate Analog Output  
 3rd Digit = 1 Select Analog Output 1 for Scaling as per Step 3

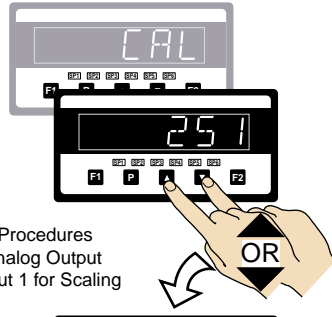

Step 10

Enter analog output low signal calibration mode

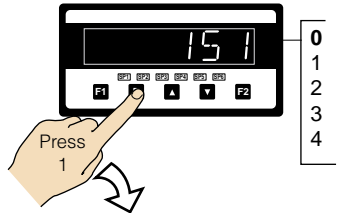

- 0 -
- 1 Analog Output 1
- 2 Analog Output 2
- 3 -
- 4 -

Step 11

Ensure the low analog output signal reading [CAL] on the multimeter display is 4.00 mA.

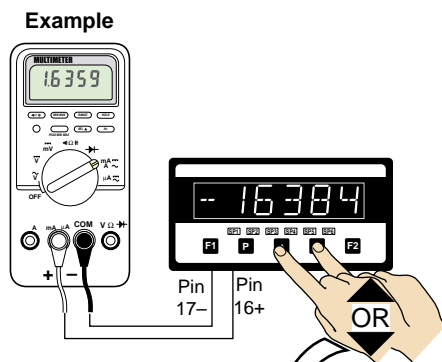

Step 12

If not correct, press the **▲** OR **▼** button on the TD 6500 until the reading on the multimeter display is correct.

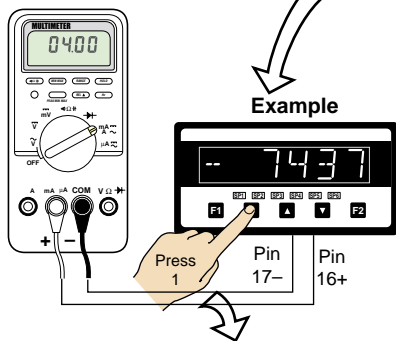

Step 13

Save the low analog output signal setting. Enter analog output high signal calibration mode

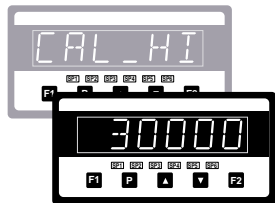

From Step 13

Step 14

Ensure the high analog output signal reading [CAL\_HI] on the multimeter display is 20 mA.

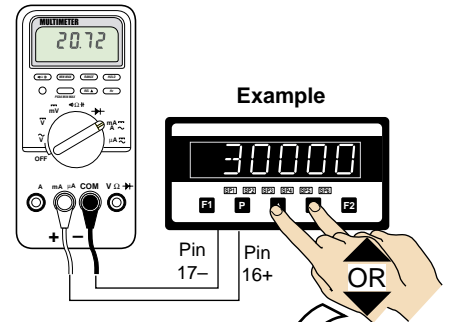

Step 15

If not 20 mA, press the **▲** or **▼** button on the TDD6500 until the reading on the multimeter display is correct.

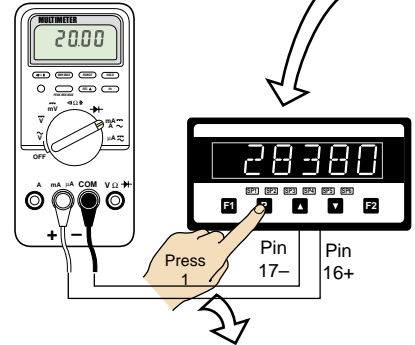

Step 16

Return to the calibration mode [CAL] menu

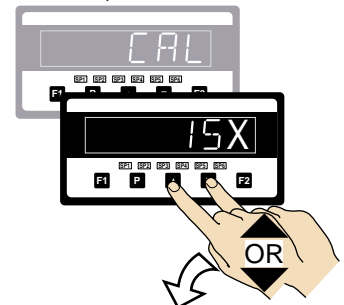

Step 17

Reset calibration mode setting to [000]

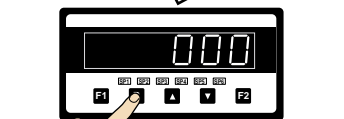

Step 18

Save calibration mode [000] setting and enter Code 1

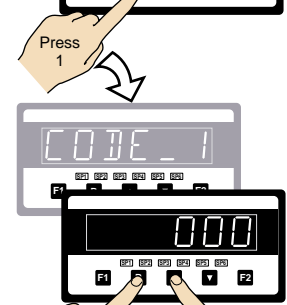

Step 19

Exit Code 1 and return to operational display

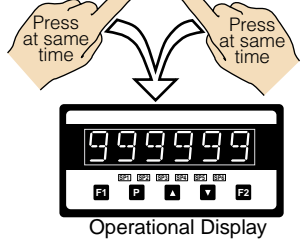

To Step 14



## Select the Data Source for the Analog Output

The following example procedure describes how to select the data source for analog output 1.

### Example Procedure:

Configure Analog Output 1 with channel 1 [CH1] as the data source by setting Code 1 to [X54]. See diagram below for data source selection options.

**START HERE**

**Step 1**  
Enter Brightness Mode

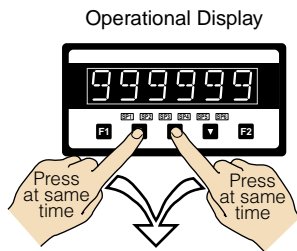

**Step 2**  
Pass Brightness and Calibration Modes and enter Code 1

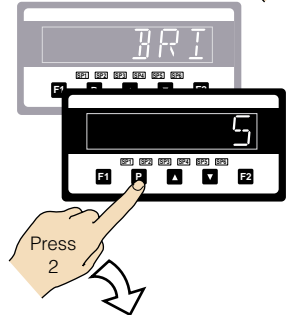

**Step 3**  
Set Code 1 to [X54]:  
1st Digit = X Not relevant  
2nd Digit = 5 Selects data source mode  
3rd Digit = 4 Selects analog output 1

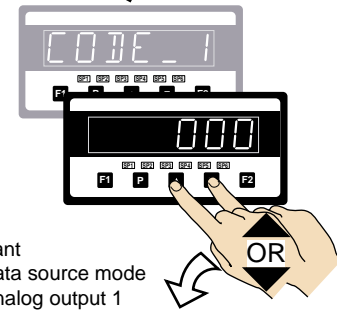

**Step 4**  
Enter the Data Source mode

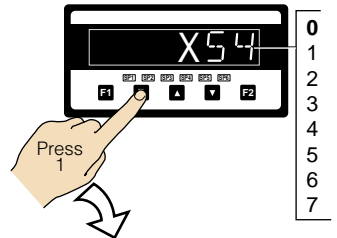

- 0 Primary Display
- 1 Second Display
- 2 Third Display
- 3 Peak/Valley
- 4 Analog Output 1
- 5 Analog Output 2
- 6 Totalizer 1
- 7 Totalizer 2

**Step 5**  
Select [CH1] as the Data Source for Analog Output 1 from the options listed in the Select Data Source diagram below.

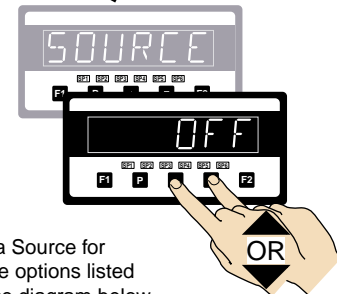

## Programming Tips for all Configuration Programming

To enter the **main programming mode** press the **P** and **A** buttons at the same time. To exit and return to the operational display, press the **P** and **A** buttons again at the same time. (See also note below at Step 9).

At the end of any procedure (Step 8 in this procedure) the **P** button must be pressed before the **P** and **A** buttons are pressed, otherwise the meter returns to the operational display without saving the new settings.

From Step 5

**Step 6**  
Return to Code 1

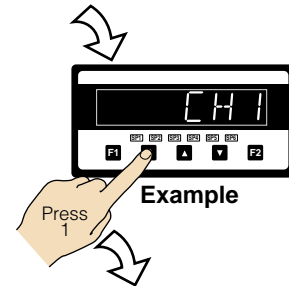

**Step 7**  
Select [000] to leave Code 1

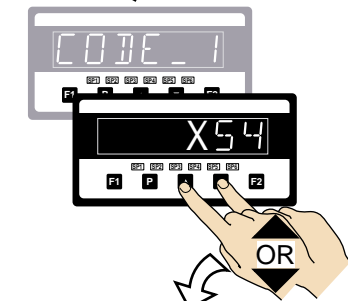

**Step 8**  
Save Data Source setting. Enter Code 2

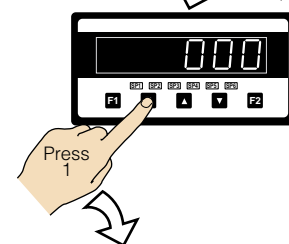

**Step 9**  
Exit Code 2. Return to Operational Display

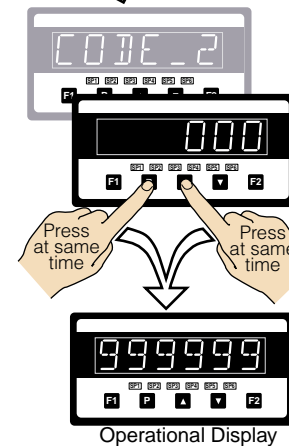

Operational Display

### Select Data Source

**P** SOURCE OFF

[DISP] ←

[RESULT]

Use the **↑ ↓** buttons to cycle through the menu

Use the **← →** buttons to select a register (1 to 244) as the data source

[1 to 244]

[TARE]

[PEAK] [VALLEY]

[CH1] [CH2] [CH3] [CH4] [TOT\_1] [TOT\_2] [PEAK] [VALLEY]

Communication with the controller is available via the serial port using either isolated RS-232 or RS-485 in ASCII mode format.

Using the serial port requires the controller to be set in the ASCII mode in Code 3 of the main programming mode.

## What is the ASCII Mode?

The ASCII mode is a simple isolated ASCII communication protocol using the standard ASCII character set. This mode provides external communication between the controller and a PC allowing remote programming to be carried out.

TD6500 controllers use a serial communication channel to transfer data from the controller to another device. With serial communications, data is sent one bit at a time over a single communications line. The voltage is switched between a high and low level at a predetermined transmission speed (baud rate) using ASCII encoding. Each ASCII character is transmitted individually as a byte of information (eight bits) with a variable idle period between characters. The idle period is the time between the receiving device receiving the stop bit of the last byte sent and the start bit of the next byte. The receiving device (for example a PC) reads the voltage levels at the same interval and then translates the switched levels back to an ASCII character. The voltage levels depend on the interface standard being used.

Table 1 lists the voltage level conventions used for RS-232 and RS-485. The voltage levels listed are at the receiver.

Logic	Interface State	RS-232	RS-485
1	Mark (idle)	TXD, RXD: -3 to -15 V	a+b < -200 mV
0	Space (active)	TXD, RXD: +3 to +15 V	a-b > +200 mV

Table 2 provides a list of the most commonly accessed ASCII mode registers in the controller.

ASCII Reg. N#	Function
1	Alarm Status
2	Display Register
3	Processed Data Result
4	Processed Data – Channel 1
5	Processed Data – Channel 2
39	Processed Data – Channel 3
40	Processed Data – Channel 4
6	Setpoint 1
7	Setpoint 2
8	Setpoint 3
9	Setpoint 4
10	Setpoint 5
11	Setpoint 6
12	Peak
13	Valley
14	Tare
15	Reserved for Future Use
16	Total 1
17	Total 2

## Character Frame Formats

Each ASCII character is 'framed' with:

- A start bit.
- An optional error detection parity bit.
- And one or more ending stop bits.

For communication to take place, the data format and baud rate (transmission speed) must match that of the other equipment in the communication circuit. Figure 4 shows the character frame formats used by the meter.

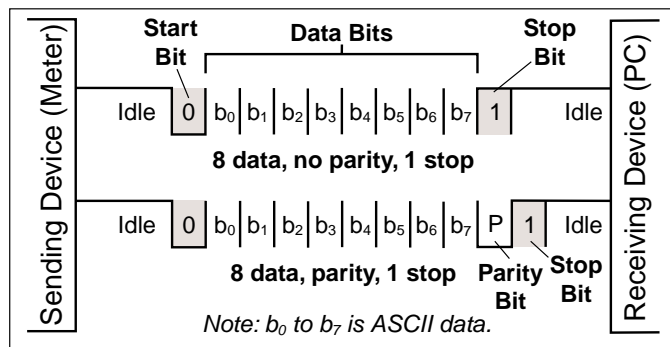

Figure 4 – Character Frame Formats

### Start Bit and Data Bits

Data transmission always begins with the start bit. The start bit signals the receiving device to prepare to receive data. One bit period later, the least significant bit of the ASCII encoded character is transmitted, followed by the remaining data bits. The receiving device then reads each bit position as they are transmitted and, since the sending and receiving devices operate at the same transmission speed (baud rate), the data is read without timing errors.

### Parity Bit

To prevent errors in communication, the sum of data bits in each character (byte) must be the same: either an odd amount or an even amount. The parity bit is used to maintain this similarity for all characters throughout the transmission.

It is necessary for the parity protocol of the sending and receiving devices to be set before transmission. There are three options for the parity bit, it can be set to either:

- None – which means there is no parity.
- Odd – which means the sum of bits in each byte is odd.
- Even – which means the sum of bits in each byte is even.

After the start and data bits of the byte have been sent, the parity bit is sent. The transmitter sets the parity bit to 1 or 0 making the sum of the bits of the first character odd or even, depending on the parity protocol set for the sending and receiving devices.

As each subsequent character in the transmission is sent, the transmitter sets the parity bit to a 1 or a 0 so that the protocol of each character is the same as the first character: odd or even.

The parity bit is used by the receiver to detect errors that may occur to an odd number of bits in the transmission. However, a single parity bit cannot detect errors that may occur to an even number of bits. Given this limitation, the parity bit is often ignored by the receiving device. The user sets the parity bit of incoming data and sets the parity bit to odd, even or none (mark parity) for outgoing data.

Parity is set in the Calibration Mode.

### Stop Bit

The stop bit is the last character to be transmitted. The stop bit provides a single bit period pause to allow the receiver to prepare to re-synchronize to the start of a new transmission (start bit of next byte). The receiver then continuously looks for the occurrence of the start bit.



**Note:**  
TD6500 controllers use only one stop bit.

## Command Response Time

The controller uses half-duplex operation to send and receive data. This means that it can only send or receive data at any given time. It cannot do both simultaneously. The controller ignores commands while transmitting data, using RXD as a busy signal.

When the controller receives commands and data, after the first command string has been received, timing restrictions are imposed on subsequent commands. This allows enough time for the controller to process the command and prepare for the next command.

See Figure 5. At the start of the time interval  $t_1$ , the sending device (PC) prints or writes the string to the com port, thus initiating a transmission. During  $t_1$  the command characters are under transmission and at the end of this period the command terminating character is received by the controller. The time duration of time interval  $t_1$  is dependent on the number of characters and baud rate of the channel:

$$t_1 = (10 * \# \text{ of characters}) / \text{baud rate}$$

At the start of time interval  $t_2$ , the controller starts to interpret the command, and when complete, performs the command function.

After receiving a valid command string, the controller always indicates to the sending device when it is ready to accept a new command. After a read command, the controller responds with the requested data followed by a carriage return ( $\text{\textcircled{D}}\text{H}$ ) and a line feed ( $\text{\textcircled{D}}\text{A}$ ) character. After receiving a write command, the controller executes the write command and then responds with a carriage return/line feed.

The sending device should wait for the carriage return/line feed characters before sending the next command to the controller. If the controller is to reply with data, time interval  $t_2$  is controlled by using the command terminating character: \$ or \*. The \$ terminating character results in a response time window of 50 ms minimum and 100 ms maximum. This allows enough time to release the sending driver on the RS-485 bus. Terminating the command line with the \* symbol, results in a response time window ( $t_2$ ) of 2 ms minimum and 50 ms maximum. The faster response time of this terminating character requires that sending drivers release within 2 ms after the terminating character is received.

At the start of time interval  $t_3$ , the meter responds with the first character of the reply. As with  $t_1$ , the time duration of  $t_3$  is dependent on the number of characters and baud rate of the channel:

$$t_3 = (10 * \# \text{ of characters}) / \text{baud rate}$$

At the end of  $t_3$  the meter is ready to receive the next command.

The maximum throughput of the meter is limited to the sum of the times:  $t_1, t_2, t_3$ .

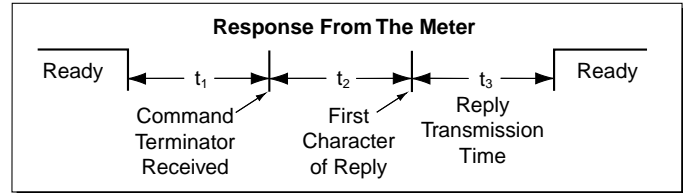

Figure 5 – Timing Diagram

## ASCII Serial Mode Read/ Write Information

### ASCII Command Character Descriptions

Table 3 (see next page) describes the functions of the command string characters. Table 4 shows examples of how the command string is constructed.

Table 4 ASCII Command String Examples	
Command String	Command String Description
SR\$	Read display value, 50 ms delay, all meters respond.
s15r\$	Read display value, 50 ms delay, meter address 15 responds.
SR12*	Read peak value, 2 ms delay, all meters respond.
Sr130*	Read Code 1 setting, 2 ms delay, all meters respond.
s2w2 -10000\$	Write 10 000 to the display register of meter address 2, 50 ms delay.
SWT Chan_1\$	Write ASCII text string Chan_1 to text register T, 50 ms.
S10w148,7*	Change brightness to 7 on meter address 10, 2 ms delay.

### Command String Construction

When sending commands to the TD6500 using a Terminal emulation program, a string containing at least one command character must be constructed. A command string consists of the following characters and must be constructed in the order shown:

- 1) A start character.
- 2) The meter (node) address (optional).
- 3) The read/write command.
- 4) The register address.
- 5) A separator character.
- 6) The data value.
- 7) The message terminator.

Figure 6 shows an example of a command string.

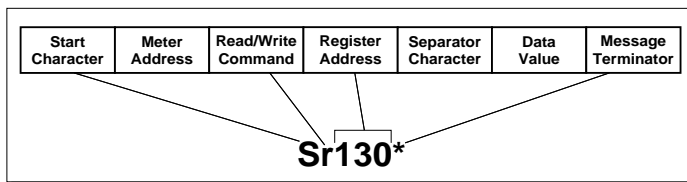

Figure 6 – Example of a Command String

### Multiple Write

The multiple write feature of the TD6500 allows multiple registers to be written to in a single ASCII command string. It is similar to a normal write command but with the following differences:

- After the first data value, a separator character is inserted instead of the message terminator. The next register address is then specified, followed by another separator character and the next data value. This procedure is repeated for each new register. The message terminator is added after the last data value in the string.
- Any number of registers can be written to using the multiple write feature, as long as the total length of the command string does not exceed 73 ASCII characters, including spaces and the message terminator.

Figure 7 shows two examples of the multiple write command.



Note:  
The multiple write feature cannot be used with special ASCII registers (H to X).

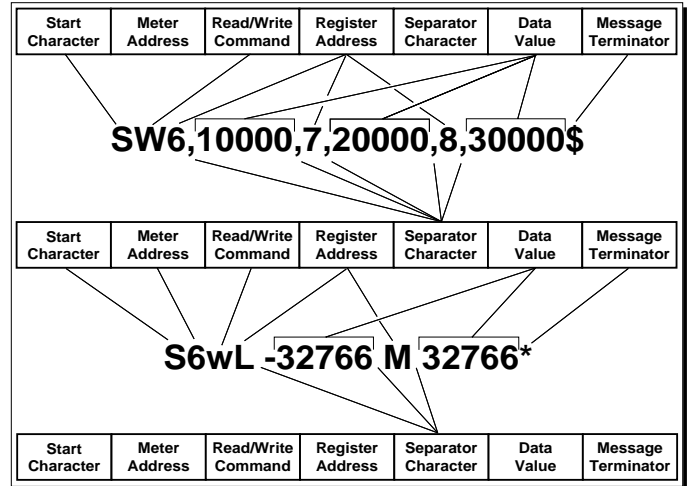

Figure 7 – Examples of Multiple Write Command

Table 3 Command Character Descriptions		
Command	Description	Function
S or s	Start Character	The <b>start character</b> must be the first character in the string.
0 to 255	Meter (Node) Address Specifier	The next character assigns an address to a specific meter. If the character following the start character is not an ASCII number, then address 0 is assumed.  All meters respond to address 0.
R or r for read  W or w for write	Read/Write Command	The next character is the <b>read/write command</b> character.  The <b>read command</b> reads a register from the meter.  The <b>write command</b> writes to a register of the meter.  Using any other character for the read or write character will abort the operation
ASCII number 1 to 65535	Register Address	The <b>register address</b> for the read/write operation is specified next. It can either be an ASCII number from 1 to 65535 or register 1 to 18 can be accessed by entering an ASCII letter from A to R (not case sensitive).  If the address character is omitted in a read command, the meter will always respond with the data value currently on the display.  The register address must be specified for a write command.
Space or ","	Separator Character	After the register address in a write command, the next character must be something other than an ASCII number. This is used to separate the register address from the data value. It can be a <b>space</b> or a "," or any other character except a "\$" or a "*".
Range between -9999999 to 9999999	Data Value	After the separator character, the <b>data value</b> is sent. It must be an ASCII number in the range of -9999999 to 9999999 (Fixed Point Register).  Note: The range will vary depending on which register is accessed.
\$ or *	Message Terminator	The last character in the message is the <b>message terminator</b> . This must be either \$ or *.  If the \$ is used as a terminator, a minimum delay of 50 ms is inserted before a reply is sent.  If the * is used as a terminator, a minimum delay of 2 ms is inserted before a reply is sent.  The \$ and * characters must not appear anywhere else in the message string.
CR/LF	Meter Response	After the meter has completed a read or write instruction, it responds by sending a <b>carriage return/ line feed</b> back to the host. If the instruction was a read command, the CR/LF follows the last character in the ASCII string. If it was a write command, the CR/LF is the only response sent back to the host. The host must wait for this before sending any further commands to the meter.  A read or write to a not valid or non-existent register, produces a null character followed by a CR/LF.

## Serial Port Settings

The following serial port settings are configured in the calibration mode of the main programming mode (see diagram below).

### Baud Rate

The baud rate range is selectable from 300 to 19200. The default baud rate is 9600.

#### Main Programming Mode

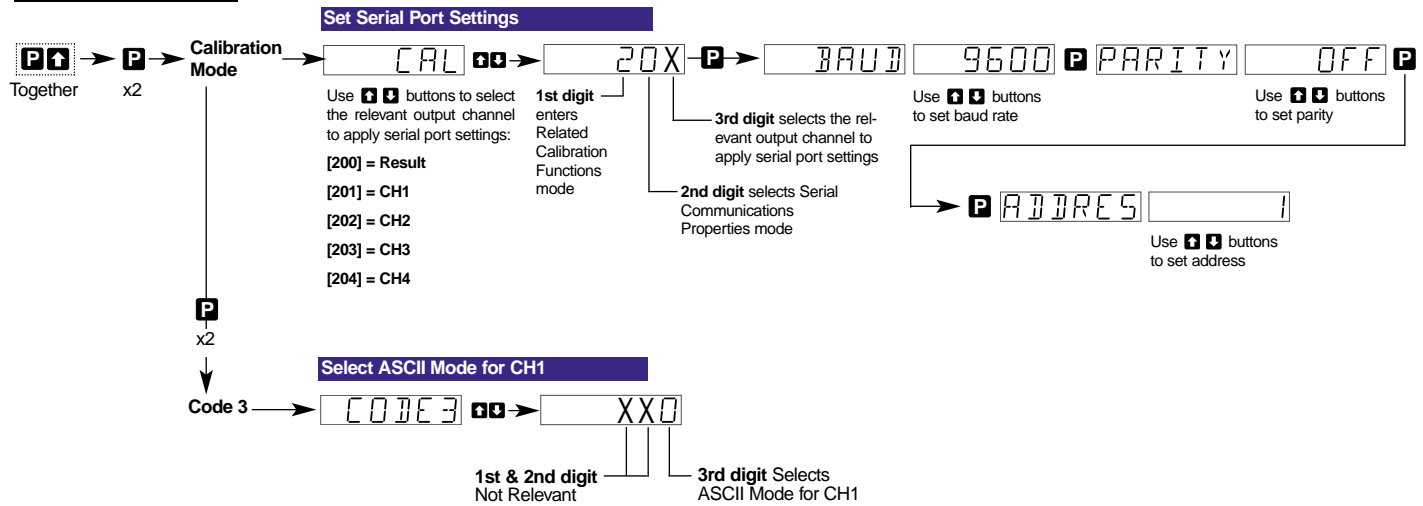

### Parity

The default parity setting is [oFF]. Parity [odd] or [EVEN] can also be selected.

### Address

For RS-485 serial communications the default address setting is 1, but can be set to anywhere between 1 and 255.

## RS-232 Interconnections

### Hardware Requirements

The following hardware is required to set the TD6500 up for simple RS-232 communications (see Figure 7):

- TD6500 with RS-232 serial output module option installed.
- RJ-11 to DB-25 interface connector (and possibly a DB-25 to DB-9 interface connector depending on PC serial port).
- Standard 4-wire cable with male RJ-11 connectors (see Figure 9 and 10, and Tables 5 and 6 for a wiring diagram and pin descriptions).
- PC running a terminal program.

Figure 8 shows a simple RS-232 connection between a TD6500 controller and a PC.

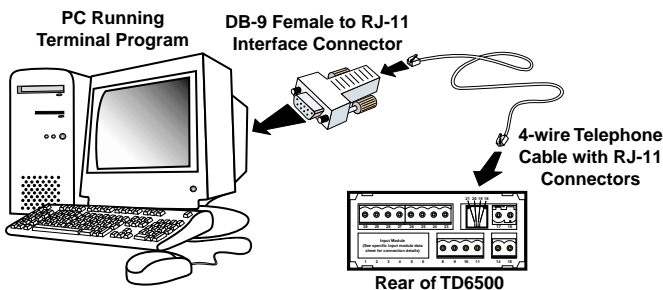

Figure 8 – RS-232 Hardware Connections

## RS-485 Interconnections

### Hardware Requirements

The following hardware is required to set the TD6500 up for simple RS-485 communications (see Figure 9):

- A number of TD6500 controllers with an RS-485 serial output module option installed (this can be up to 64 controllers).
- A number of RJ-11 dual outlet adapters to connect the meters in series (amount depends on the number of controllers installed).
- RJ-11 to DB-25 interface connector.
- Isolated converter (RS-485 to RS-232)
- Possibly a DB-25 to DB-9 interface connector depending on PC serial port.
- Lengths of standard 2-wire telephone cable with male RJ-11 connectors (enough to connect the controllers in series and connect to the RJ-11 to DB-25 interface connector). See Figure 10 and Table 5 for a wiring diagram and pin descriptions.
- PC running a terminal program.

Figure 8 shows a number of TD6500 controllers with the hardware required to connect directly to a PC using RS-485.



**Note:**

In theory, up to 64 controllers can be connected together. The controllers can be connected together in series or parallel using RJ-11 type connectors or hardwiring (each TD6500 can only be hardwired if it has a screw terminal instead of an RJ-11 connector). Figure 7 has the controllers connected in series using RJ-11 type connectors.

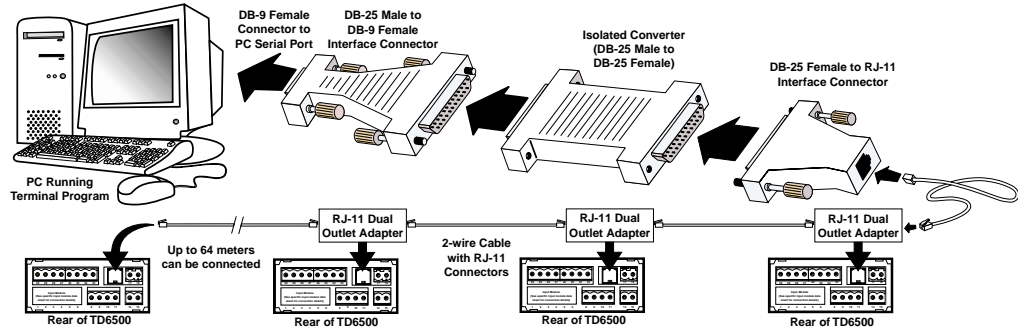

**Figure 9 – RS-485 Hardware Connections**

Table 5 lists the pinouts for an RS-232 or RS-485 to RJ-11 socket configuration.

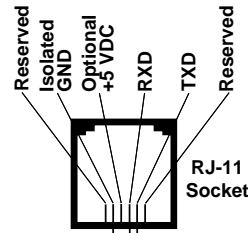

See Table 5 for TD6500 pin numbers

**Figure 10 – RJ-11 Connections**

Table 5 Serial Communication Pinouts (RJ-11 Socket)		
Pin No.	RS-232	RS-485
19	Reserved for future use	Reserved for future use
20	RXD. Received Serial	B (Low)
21	TXD. Transmitted Serial	A (High)
22	Optional +5 VDC to power external converters (jumper on RS-232 or RS-485 boards must be soldered)	Optional +5 VDC to power external converters (jumper on RS-232 or RS-485 boards must be soldered)
23	Isolated Ground	Isolated Ground
24	Reserved for future use	Reserved for future use

Table 6 lists the pinouts for an RS-232 to 9-pin or 25-pin D connector.

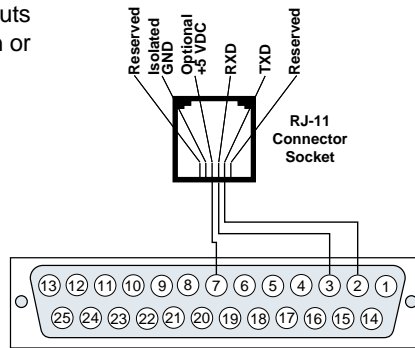

25-Pin D Connector  
(See Table 6 for pin descriptions)  
(Viewed from the pin side of a female connector)

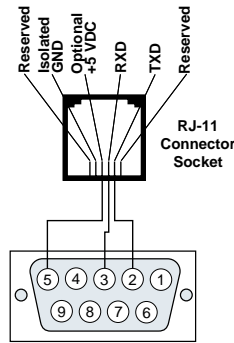

9-Pin D Connector  
(See Table 6 for pin descriptions)  
(Viewed from the pin side of a female connector)

**Figure 11 – RJ-11 to 9-pin and 25-pin D Connectors**

Table 6 RS-232 to 25-Pin & 9-Pin D Connectors		
25-Pin	Pin Name	9-Pin
1	Frame Ground	-
2	Transmit Data	3
3	Receive Data	2
4	Request to Send	7
5	Clear to Send	8
6	Data Set Ready	6
7	Signal Ground	5
8	Data Carrier Detect	1
9	Reserved	-
10	Reserved	-
11	Unassigned	-
12	Sec. Carrier Detect	-
13	Sec. Carrier Send	-
14	Sec. Transmit Data	-
15	Transmitter Clock	-
16	Sec. Receive Data	-
17	Receiver Clock	-
18	Local Loopback	-
19	Sec. Request to Send	-
20	Data Terminal Ready	4
21	Remote Loopback/Signal Quality Detect	-
22	Ring Indicator	9
23	Data Rate Select	-
24	Transmitter Clock	-
25	Test Mode	-

### Setup RS-232 Interface

Carry out the following procedures to establish communications between the TD6500 and a PC using RS-232 interface:

See Figures 8, 9, 10, 11 and Tables 5 and 6.

#### STEP A Connect the Meter to the PC

- 1) Connect one end of the standard 4-wire telephone cable to the RJ-11 serial output port on the TD6500.
- 2) Connect the other end of the standard 4-wire telephone cable to the RJ-11 to DB-25 interface connector.
- 3) Connect the DB-25 interface connector to the serial port of the PC.

#### STEP B Make Sure the PC and TD6500 are Powered Up

- 1) Make sure the TD6500 is powered up.
- 2) Make sure the PC is powered up.

#### STEP C Check Communication Between the PC and the TD6500

- 1) Make sure the terminal program is running.
- 2) Check that communication is established between the TD6500 and the PC:

Write **SR\*** in the terminal program.

The screen displays the current meter reading.

#### STEP C Check Communication Between the PC and the TD6500

- 1) Make sure the terminal program is running.
- 2) Check that communication is established between the TD6500 and the PC:

Write **SR\*** in the terminal program.

The screen displays the current TD6500 reading.

### Configure Serial Port Settings

See procedure diagram on Pages 17 and 18.

### Select ASCII Mode

See procedure diagram on Page 18.

#### Programming Tip

When configured in the ASCII mode (Code 3 set to XX0), the serial port settings do not require a time delay to be set. When configuring the serial port settings in the calibration mode [CAL][20X] the time delay mode does not appear in the menu.

The ASCII Mode uses the terminating characters with built-in time delays:

\$ = 50 milliseconds

\* = 2 milliseconds

### Setup RS-485 Interface

Carry out the following procedures to establish communications between a number of meter sand a PC using RS-485 interface:

See Figures 8, 9, 10, 11 and Tables 5 and 6.

#### STEP A Connect the TD6500 Controllers Together

- 1) Connect the controllers together using the 2-wire telephone cables as shown in Figure 8.

#### STEP B Connect the Meter to the Isolated Converter

- 1) Connect one end of the standard 2-wire telephone cable to the RJ-11 serial output port on the first TD6500.
- 2) Connect the other end of the standard 2-wire telephone cable to the RJ-11 to female DB-25 interface connector.
- 3) Connect the RJ-11 to female DB-25 interface connector to the end of the isolated convertor marked: **LOGIC OUTPUT FROM METER**.
- 4) Connect the isolated converter to the DB-25 to DB-9 interface connector.
- 5) Connect the DB-9 end of the DB-25 to DB-9 interface connector to the serial port of the PC.

# Configure Serial Port Settings

**START HERE**

**Step 1**  
Enter Brightness Mode

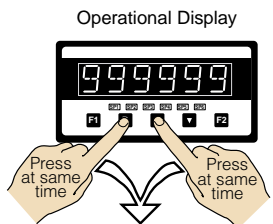

**Step 2**  
Pass Brightness, enter Calibration Mode

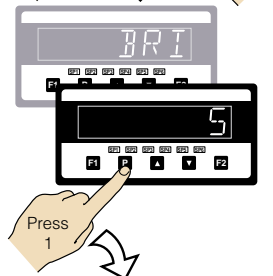

**Step 3**  
Set Calibration Mode to [20X]:  
1st Digit = 2 Selects Related Calibration Functions  
2nd Digit = 0 Selects Serial Comms. Properties  
3rd Digit = X Select relevant channel

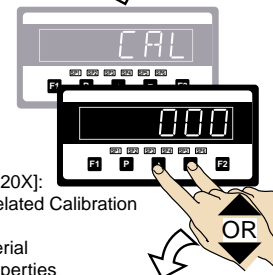

**Example**  
Enter CAL and select channel CH1.

**Step 4**  
Enter the Baud Rate setting menu

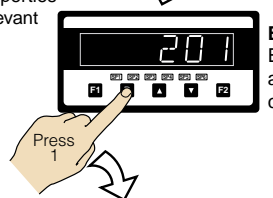

**Step 5**  
Set the baud rate to [2400]

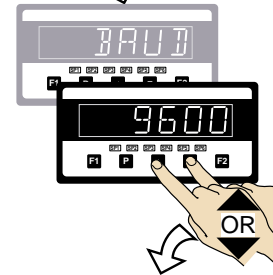

**Example**

**Step 6**  
Save the baud rate. Enter the Parity setting menu

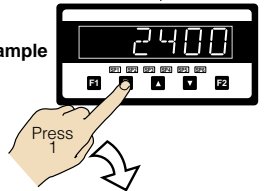

**Step 7**  
Set parity to [ODD]

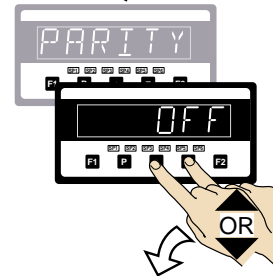

**Step 8**  
Save the parity setting. Enter the Time Delay setting mode

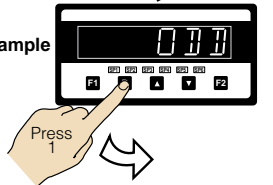

From Step 8

Note, the time delay setting is not relevant to serial port settings when the TD6500 is setup for the ASCII mode in Code 3

**Step 9**  
Pass thru the Time Delay setting mode. Enter the Address setting mode

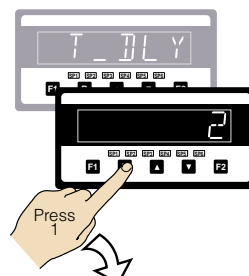

**Step 10**  
Select an Address setting

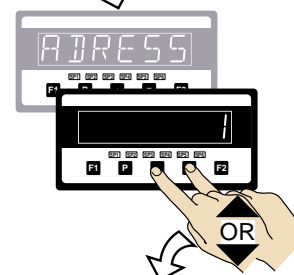

**Example**

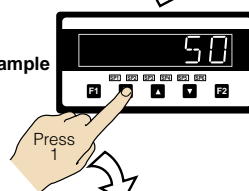

**Step 11**  
Save the address setting. Return to the Calibration Mode [CAL]

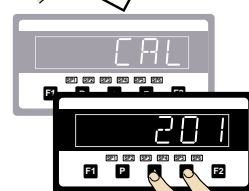

**Step 12**  
Reset Calibration Mode setting to [XX0]

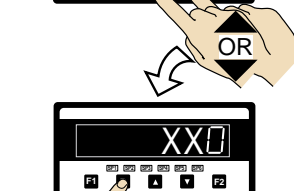

**Step 13**  
Save Calibration Mode [XX0] setting and enter Code 1

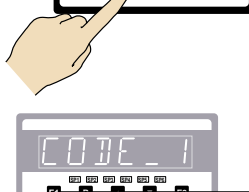

**Step 14**  
Exit Code 1 and return to Operational Display

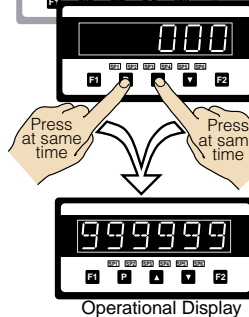

To Step 9

# Select ASCII Mode

**START HERE**

**Step 1**  
Enter Brightness Mode

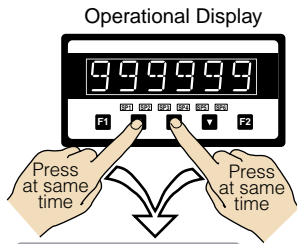

**Step 2**  
Pass Brightness thru to Code 2 and enter Code 3

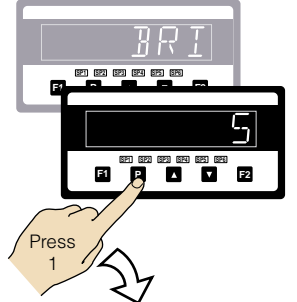

**Step 3**  
Set Code 3 to [XX0]:  
1st Digit = X Not relevant  
2nd Digit = X Not relevant  
3rd Digit = 0 Selects ASCII Mode

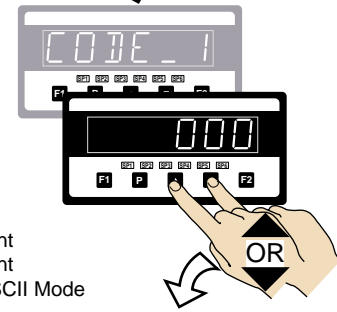

**Step 4**  
Save Code 3 settings

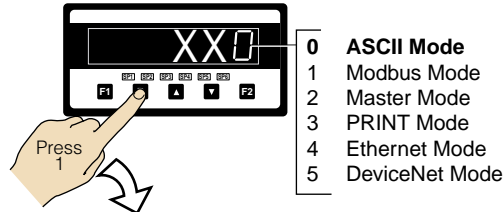

**Step 5**  
Exit Code 4 and return to Operational Display

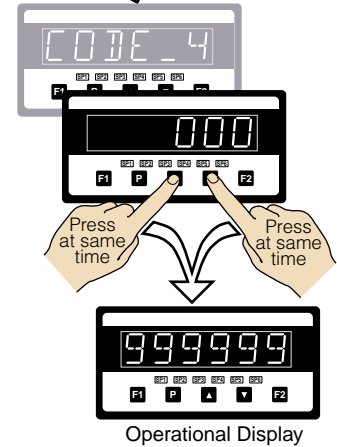

Following is a list of the 32-bit signed integer data registers accessed through the serial port and used as the data source for all magnet position displays.

Also listed are the registers holding the activation values for set-points 1 to 6:

Number of Magnets	Magnet System Description	Name	Description	Register Number
<b>1 Magnet System</b>	Magnet 1 position	CH1	Channel 1 data. 32-bit register holds the processed data for channel 1.	253
	Magnet 1 velocity	CH3	Channel 3 data. 32-bit register holds the processed data for channel 3.	251
<b>2 Magnet System</b>	Magnet 1 position	CH1	Channel 1 data. 32-bit register holds the processed data for channel 1.	253
	Magnet 2 position	CH2	Channel 2 data. 32-bit register holds the processed data for channel 2.	252
	Magnet 1 velocity	CH3	Channel 3 data. 32-bit register holds the processed data for channel 3.	251
	Magnet 2 velocity	CH4	Channel 4 data. 32-bit register holds the processed data for channel 4.	250
	Magnet 2 position minus magnet 1 position	RESULT	Result data. 32-bit register holds the processed data for result channel.	254
<b>3 Magnet System</b>	Magnet 1 position	CH1	Channel 1 data. 32-bit register holds the processed data for channel 1.	253
	Magnet 2 position	CH2	Channel 2 data. 32-bit register holds the processed data for channel 2.	252
	Magnet 3 position	CH3	Channel 3 data. 32-bit register holds the processed data for channel 3.	251
	Magnet 1 velocity	CH4	Channel 4 data. 32-bit register holds the processed data for channel 4.	250
	Magnet 2 position minus magnet 1 position	RESULT	Result data. 32-bit register holds the processed data for result channel.	254
	Magnet 3 position minus magnet 2 position	VARIABLE4	Macro variable 4. 32-bit register used by the macro for variable space.	87
<b>4 Magnet System</b>	Magnet 1 position	CH1	Channel 1 data. 32-bit register holds the processed data for channel 1.	253
	Magnet 2 position	CH2	Channel 2 data. 32-bit register holds the processed data for channel 2.	252
	Magnet 3 position	CH3	Channel 3 data. 32-bit register holds the processed data for channel 3.	251
	Magnet 4 position	CH4	Channel 4 data. 32-bit register holds the processed data for channel 4.	250
	Magnet 2 position minus magnet 1 position	RESULT	Result data. 32-bit register holds the processed data for result channel.	254
	Magnet 3 position minus magnet 2 position	VARIABLE4	Macro variable 4. 32-bit register used by the macro for variable space.	87
	Magnet 4 position minus magnet 3 position	VARIABLE5	Macro variable 5. 32-bit register used by the macro for variable space.	88

Setpoint Name	Description	Register Number
SETPOINT1	32-bit register holds the setpoint activation value for setpoint 1.	6
SETPOINT2	32-bit register holds the setpoint activation value for setpoint 2.	7
SETPOINT3	32-bit register holds the setpoint activation value for setpoint 3.	8
SETPOINT4	32-bit register holds the setpoint activation value for setpoint 4.	9
SETPOINT5	32-bit register holds the setpoint activation value for setpoint 5.	10
SETPOINT6	32-bit register holds the setpoint activation value for setpoint 6.	11

## Installation

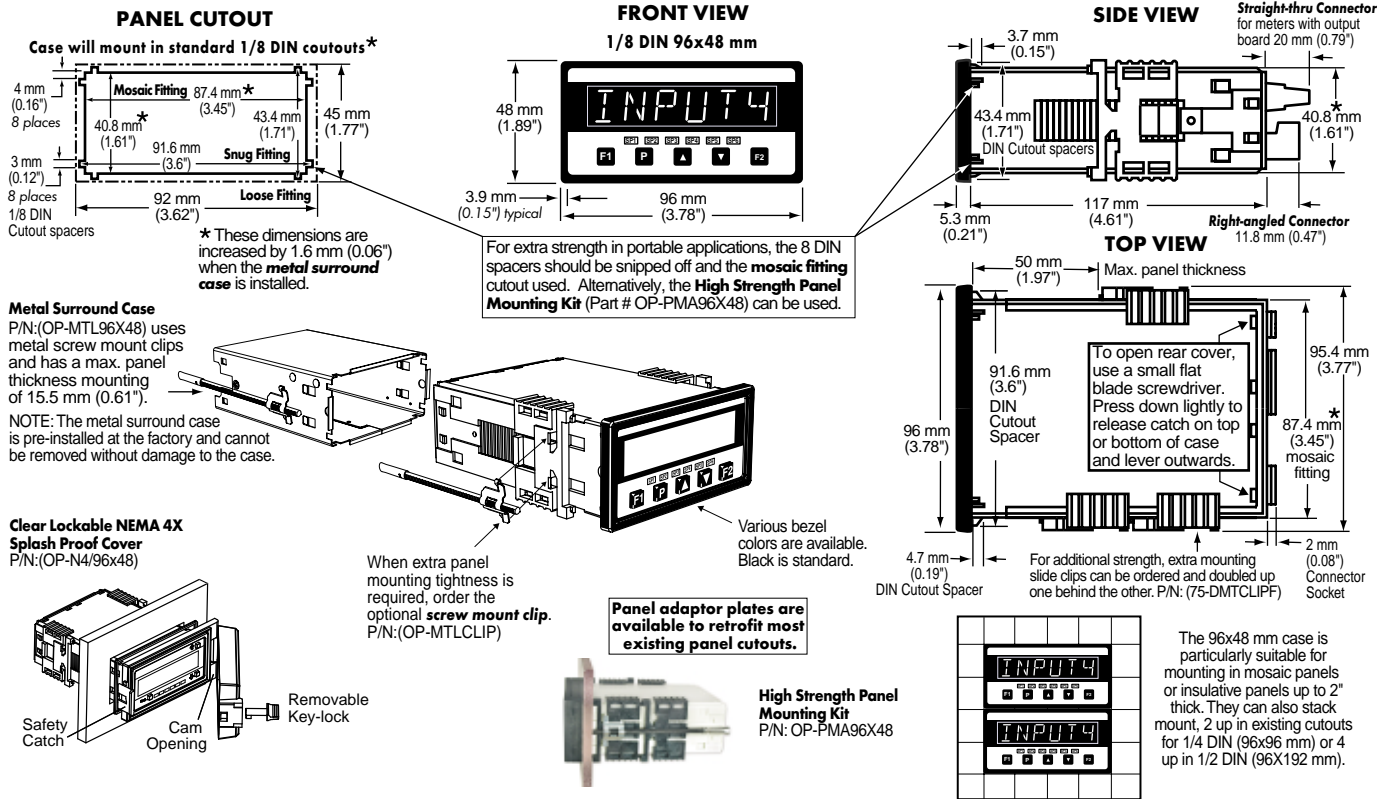

## Installation Procedure



### WARNING

AC and DC power supply voltages are hazardous. Make sure the power supply is isolated before connecting to the meter.

### STEP A Prepare the Panel

- Cut a hole in the panel to suit the panel cutout. See panel cutout sizes above.

### STEP B Install the Meter

- Remove both mounting clips from the meter. ①
- Push the meter into the panel cutout from the front of the panel. ②
- Attach both mounting clips to the meter from the rear of the panel and push them towards the front of the panel until the meter is firmly held. ③

### STEP C Connect the Cables

- Connect all input and output signal cables to the connector pins (See *Connector Pinouts* for details).
- Connect the power cables to the connector pins (See *Connector Pinouts* for details).

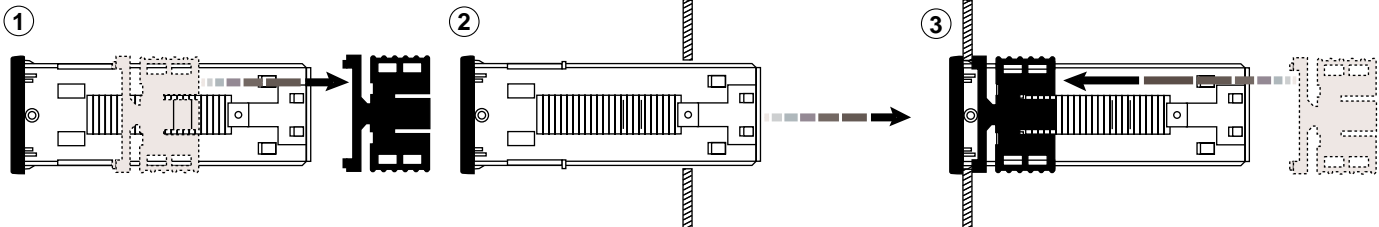

# Connector Pinouts

Connector	Pin	Name	Description
<b>Input Signal</b>	1	Pulse +	See Figure 12 for an example input connection diagram
	2	Pulse -	
	3	Interrogate +	
	4	Interrogate -	
	5	+24 V	
	6	Ground	
	7	Not Used	

<b>Function Pins</b>	8	Program Lock	By connecting the PROGRAM LOCK pin to the COMMON pin (pin 11 on the main PCB), the PROGRAM LOCK pin allows the controller's programmed parameters to be viewed but not changed.
	9	Hold Reading	By connecting the HOLD READING pin to the COMMON pin (pin 11), the HOLD READING pin allows the controller's display to be frozen. However, A/D conversions continue and as soon as pin 9 is disconnected from pin 11 the updated reading is instantly displayed.
	10	Display Test and Reset	The DISPLAY TEST and RESET pin provides a test of the meter's display and resets the microprocessor when the DISPLAY TEST and RESET pin is connected to the COMMON pin (pin 11).
	11	Common	To activate the HOLD, TEST and RESET, or LOCKOUT pins from the rear of the controller, the respective pins have to be connected to the COMMON pin.
	12	Capture	The CAPTURE pin is a general digital input pin. It is configured via setpoint control or a macro for setpoint activation and register reset functions.
	13	Not Used	

<b>AC / DC Power Input</b>	14	AC Neutral / DC Negative	Standard High Voltage: 85-265 VAC or 95-370 VDC. Optional Low Voltage: 9-32 VAC or 10-60 VDC.
	15	AC Line / DC Positive	

<b>Analog Outputs</b>	16	Positive (+)	Analog Output 1
	17	Negative (-)	Analog Output 1&2
	18	Positive (+)	Analog Output 2

Serial Outputs	Pin No.	RS-232	RS-485
	19	Reserved for future use	Reserved for future use
20	RXD. Received Serial	B (Low)	
21	TXD. Transmitted Serial	A (High)	
22	+5 VDC to power external converters	+5 VDC to power external converters	
23	Isolated Ground	Isolated Ground	
24	Reserved for future use	Reserved for future use	

Connector	Pin	Description
<b>Relay Outputs</b>		Relay Modules with Five or Six 5 A Form A Relays
	25	Normally Open SP1
	26	Normally Open SP2
	27	Normally Open SP3
	28	Common SP1, SP2, SP3
	29	Normally Open SP4
	30	Normally Open SP5
	31	Normally Open SP6
32	Common SP4, SP5, SP6	

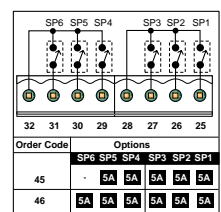

<b>Relay Modules with up to Four 5 A Form A Relays</b>	25	Common SP1
	26	Normally Open SP1
	27	Common SP2
	28	Normally Open SP2
	29	Common SP3
	30	Normally Open SP3
	31	Common SP4
	32	Normally Open SP4

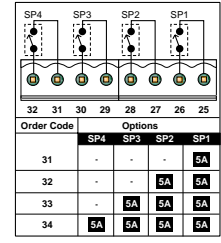

<b>Relay Modules with up to Two 5 A Form A &amp; Two 10 A Form C Relays</b>	25	Normally Open SP3
	26	Common SP1, SP3
	27	Normally Closed SP1
	28	Normally Open SP1
	29	Normally Open SP4
	30	Common SP2, SP4
	31	Normally Closed SP2
	32	Normally Open SP2

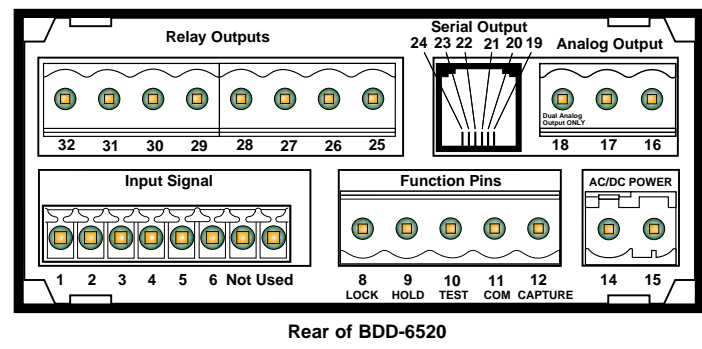
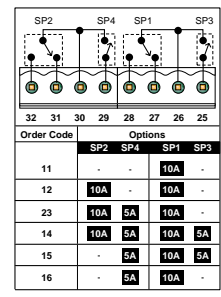

## Example Input Connections

The TD6500 magnetostrictive controller is designed to operate with most digital interface leading / trailing-edge pulse magnetostrictive transducers. The TD6500 can operate with magnetostrictive transducers from the following manufacturers:

- Balluff.
- Gefran.
- MTS Systems Corporation.
- Novotechnik.
- Patriot Sensors and Controls Corporation.
- SanTest.
- TR Electronic.

As an example, the TD6500 interfaces directly with and supplies +24 V excitation voltage to a magnetostrictive transducer. The TD6500 can be configured to receive either trailing-edge active or leading-edge active pulses.



### Note:

**The TD6500 only supports the leading and trailing edge digital RS-422 output interface options.**

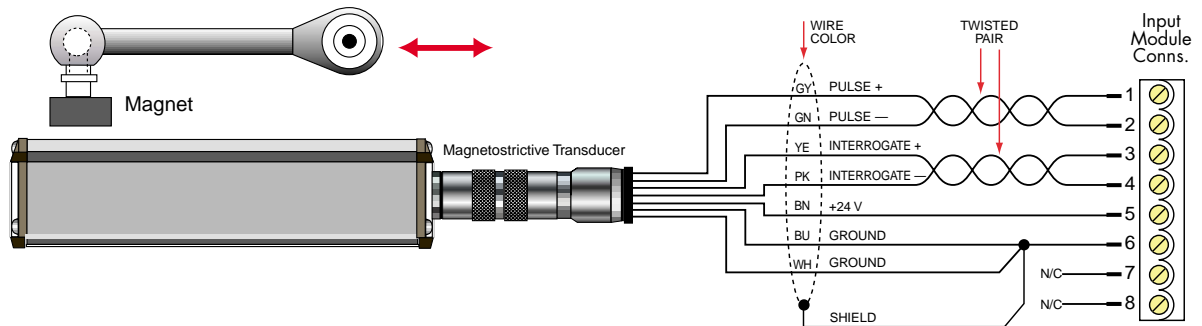

Figure 12 – TD6500 connected to a Magnetostrictive Transducer

## Advanced Functions

This operator's guide is designed to provide you with the information required to connect a TD6500 controller to a magnetostrictive transducer and configure it to operate with up to 4 magnets.

The TD6500 has a range of built-in functions available to perform advanced functions that include totalizing, linearization, data logging, and many more. The six setpoints also have built-in advanced functions that include setpoint latching, reset, tracking, hysteresis and deviation, PID, and seven timer modes.

As well as the RS-232 and RS-485 serial output options, there are a number of advanced isolated communications options available such as Modbus protocol RS-232 and RS-485, Ethernet, and DeviceNET.

Should you wish to use any of the remaining built-in functions available with all TD6500 controllers, contact Transducers Direct for more information.

This Page Intentionally Left Blank

**Transducers Direct**

264 Center Street Miami, OH 45147

Ph: 513-583-9491

Fax: 513-583-9476

E-mail: [Customerservice@transducersdirect.com](mailto:Customerservice@transducersdirect.com)