

Introducing the TDLS02 Series Ultrasonic Liquid Level Switch



SERIES: TDLS02

FEATURES

- Solid one piece molded body - rugged construction
- Low cost replacement to mechanical float with large OEM discounts
- Optional High Temperature up to 212°F (100°C) - consult factory
- Ready to use, pre-wired

APPLICATIONS

- Pump Protection
- Storage Tanks
- Compressors
- Hydraulic Supply Lines
- Boiler Water Cutoff
- Sewage Systems
- Pipe Lines

DESCRIPTION

The TDLS02 Series Liquid Level Switch, is a direct replacement for mechanical float type liquid level devices that employs proven ultrasonic technology and solid state integral electronics. The TDLS02 provides reliable operation in virtually any liquid, and eliminates failure rate due to finite mechanical

life inherent in the mechanical float design. With fully epoxy sealed electronics, combined with ultrasonic sensing technology, the TDLS02 is designed for years of maintenance-free service. The TDLS02 Series offers 2 types of outputs.

DIMENSIONS

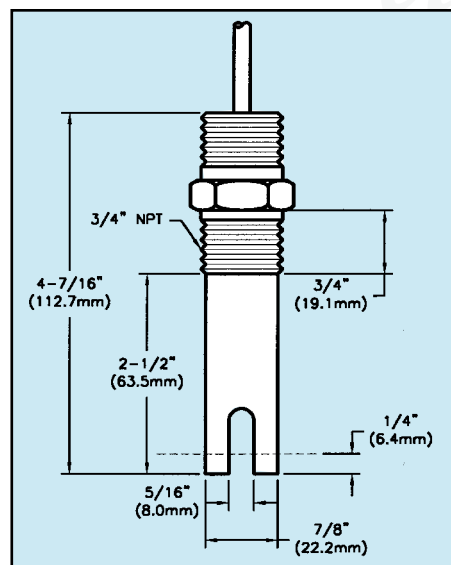

SPECIFICATIONS

Current Rating	1 amp
Repeatability	2mm or better
Delay	0.5 seconds
Input Power	5-30 VDC
Leakage Current	Less than 50 uA
Outputs	Sink - (open when dry, closed when wet) Source - (open when dry, closed when wet) Relay output, SPDT, N.O. (when dry) Transient, reverse polarity
Protection	316LSS (standard)
Sensor	-20°F to +160° F (-29°C to +71°C)
Temperature	Up to 1000 psig (6895 Kpa) - 316SS
Pressure	3/4" NPT STD (for angles, consult factory)
Mounting	

WIRING DIAGRAM

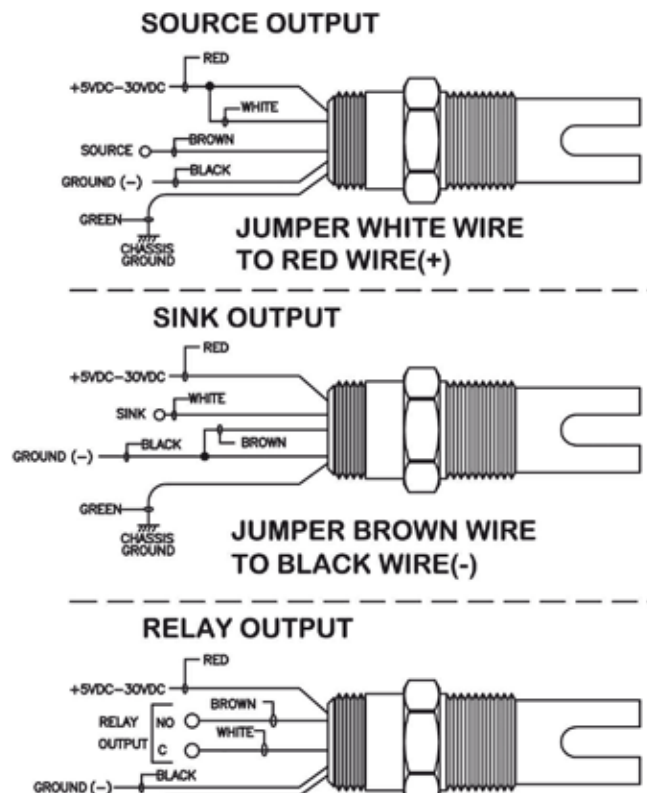

ORDERING

Series Part Number	Sensor Mounting	Sensor Material	Electronics Input	Electronics Output
TDLS0210020	3/4" NPT	316LSS	5VDC-30VDC	SPDT Relay N.O., Com (normally open when dry)
TDLS0210022	3/4" NPT	316LSS	5VDC-30VDC	Sink (open when dry, closed when wet)
TDLS0210023	3/4" NPT	316SS	5VDC-30VDC	Source (open when dry, closed when wet)